

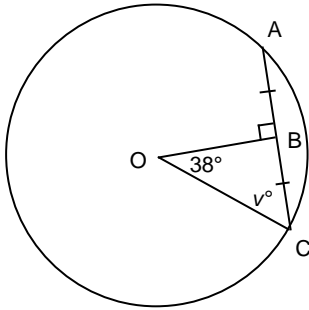

4. O is the centre of the circle.  
Determine the value of  $v^\circ$ .



- a.  $26^\circ$                       b.  $52^\circ$                       c.  $64^\circ$                       d.  $38^\circ$

5. O is the centre of the circle.  
Determine the value of  $a^\circ$ .

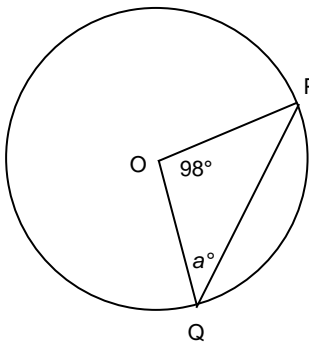

- a.  $49^\circ$                       b.  $20.5^\circ$                       c.  $41^\circ$                       d.  $69.5^\circ$

6. O is the centre of the circle.  
Determine the value of  $n$  to the nearest tenth, if necessary.

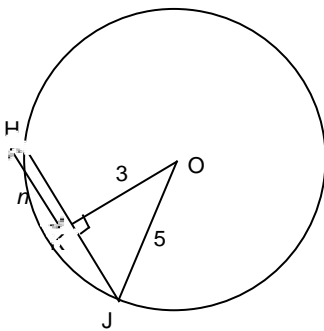

- a. 16                      b. 4                      c. 2                      d. 5.8

7. O is the centre of the circle.  
Determine the value of  $z$  to the nearest tenth, if necessary.

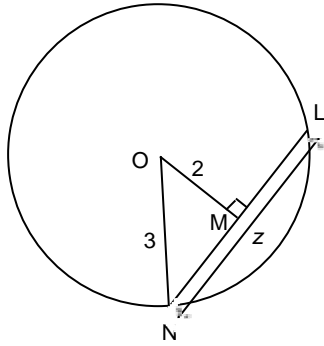

- a. 4.5      b. 3.6      c. 5      d. 1

8. O is the centre of this circle.  
Identify all the inscribed angles subtended by the minor arc QS.

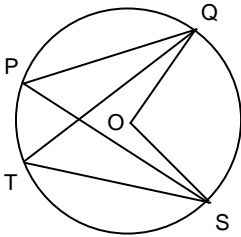

- a.  $\angle QOS$       c.  $\angle QPS$  and  $\angle QTS$   
b.  $\angle PQT$  and  $\angle PST$       d.  $\angle QPS$

9. O is the centre of this circle.  
Determine the value of  $m^\circ$ .

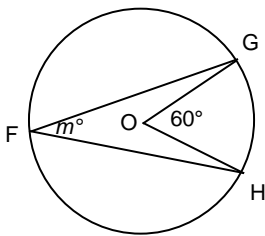

- a.  $30^\circ$       c.  $180^\circ$   
b.  $90^\circ$       d.  $60^\circ$

10. O is the centre of this circle.  
Determine the value of  $c^\circ$ .

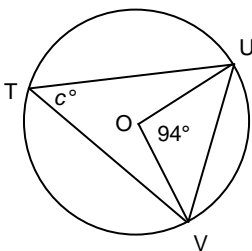

- a.  $180^\circ$       c.  $90^\circ$   
b.  $94^\circ$       d.  $47^\circ$

11. O is the centre of this circle.  
Determine the value of  $z^\circ$ .

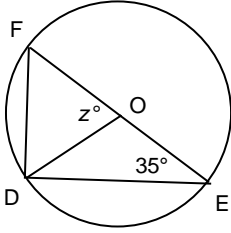

- |                |               |
|----------------|---------------|
| a. $55^\circ$  | c. $90^\circ$ |
| b. $110^\circ$ | d. $70^\circ$ |

12. O is the centre of this circle.  
Determine the value of  $g^\circ$ .

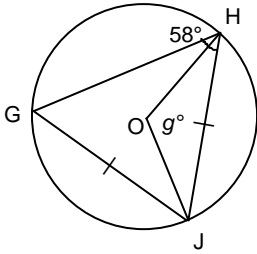

- |               |                |
|---------------|----------------|
| a. $90^\circ$ | c. $64^\circ$  |
| b. $58^\circ$ | d. $116^\circ$ |

**Short Answer**

13. O is the centre of this circle.  
Which line is a tangent?

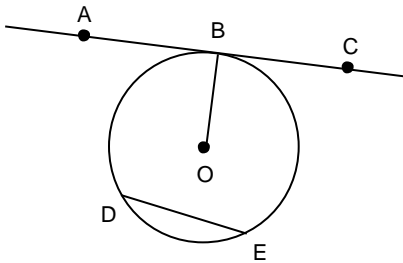

14. O is the centre of this circle. Point T is a point of tangency.  
What is the value of  $e^\circ$ ?

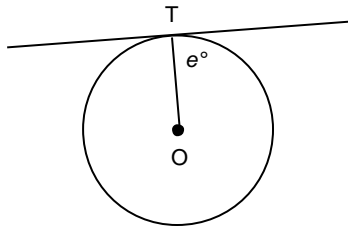

15. Is the line that passes through points U and V a tangent to the circle?

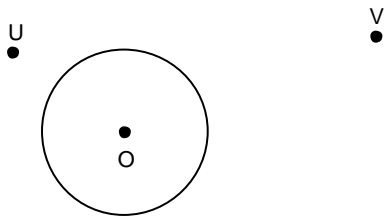

16. O is the centre of this circle and point B is a point of tangency.  
Determine the values of  $v^\circ$  and  $w^\circ$ .

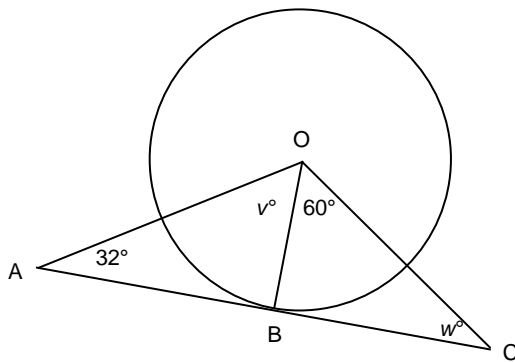

17. O is the centre of this circle and point S is a point of tangency.  
Determine the values of  $m$  and  $n^\circ$ . If necessary, give your answers to the nearest tenth.

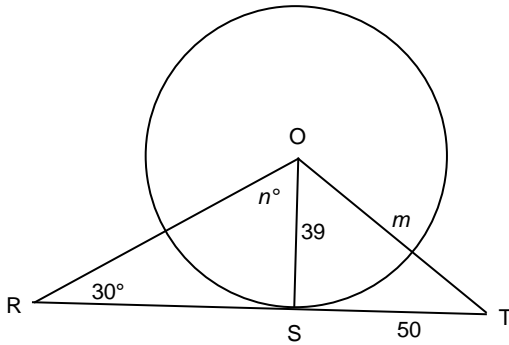

18. O is the centre of this circle.  
Which line segment is a diameter?

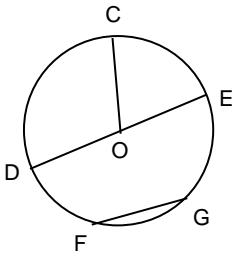

19. Point O is the centre of this circle. Without solving for  $s$ , sketch and label the lengths of any extra line segments you need to draw to determine the value of  $s$ .

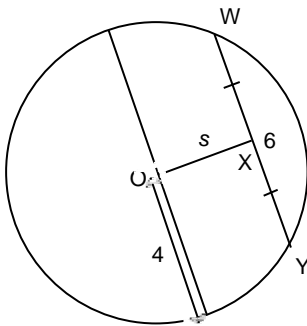

20. Label the major arc CD and the minor arc CD of this circle.

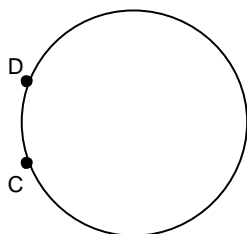

21. O is the centre of this circle. Is  $\angle ACB$  a central angle or an inscribed angle?

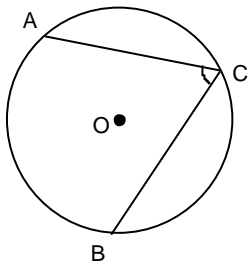

22. O is the centre of this circle.  
In this circle, identify the inscribed angle and the central angle subtended by the same minor arc.

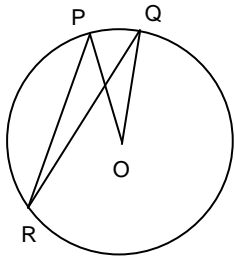

23. Point O is the centre of the circle. Arc AB is a semicircle.  
What is the measure of  $\angle AOB$ ?

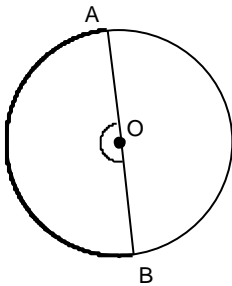

24. Point O is the centre of this circle.  
Determine the values of  $y^\circ$  and  $z^\circ$ .

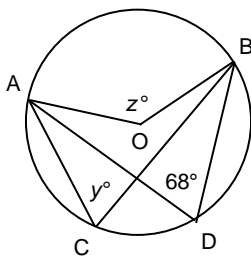

25. Point O is the centre of the circle.  
Determine the values of  $y^\circ$  and  $z^\circ$ .

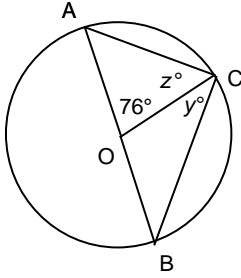

**Problem**

26. A Ruppell's Griffon Vulture holds the record for the bird with the highest documented flight altitude. It was spotted at a height of about 11 km above the Earth's surface. The radius of Earth is approximately 6400 km. How far was the vulture from the horizon, H? Calculate this distance to the nearest kilometre.

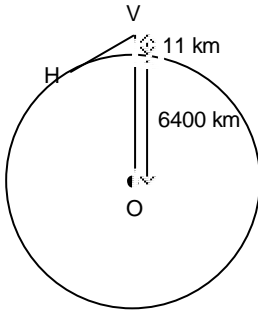

27. A circular mirror with radius 28 cm hangs from a hook.  
The wire is 48 cm long and is a tangent to the circle at points A and B.  
How far, to the nearest tenth, above the top of the mirror is the hook?

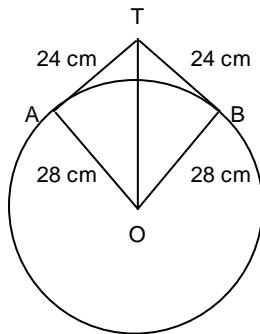

28. Draw a point at the centre of this circle. Label the point O.  
How do you know your answer is correct?

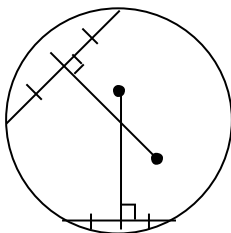



29. a) In a circle, can a chord be longer than a diameter of the circle? Explain.  
 b) In a circle, can a chord be shorter than a radius of the circle? Explain.
30. This arc is part of a circle.  
 Explain how you could locate the centre of the original circle.



31. A circle has diameter 38 cm. How far from the centre of the circle, to the nearest centimetre, is a chord 26 cm long?
32. Point O is the centre of the circle.  
 Determine the values of  $x^\circ$ ,  $y^\circ$ , and  $z^\circ$ .

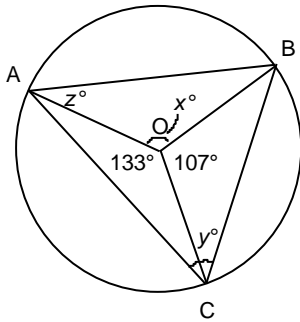

## Review for Grade 9 Math Exam - Unit 8 - Circle Geometry Answer Section

### MULTIPLE CHOICE

1. ANS: D                   PTS: 1                   DIF: Easy                   LOC: 9.SS1  
REF: 8.1 Properties of Tangents to a Circle  
TOP: Shape and Space (Measurement)   KEY: Conceptual Understanding
2. ANS: D                   PTS: 1                   DIF: Easy                   LOC: 9.SS1  
REF: 8.1 Properties of Tangents to a Circle  
TOP: Shape and Space (Measurement)   KEY: Conceptual Understanding
3. ANS: C                   PTS: 1                   DIF: Moderate               LOC: 9.SS1  
REF: 8.1 Properties of Tangents to a Circle  
TOP: Shape and Space (Measurement)   KEY: Conceptual Understanding
4. ANS: B                   PTS: 1                   DIF: Easy                   REF: 8.2 Properties of Chords in a Circle  
LOC: 9.SS1               TOP: Shape and Space (Measurement)   KEY: Conceptual Understanding
5. ANS: C                   PTS: 1                   DIF: Easy                   REF: 8.2 Properties of Chords in a Circle  
LOC: 9.SS1               TOP: Shape and Space (Measurement)   KEY: Conceptual Understanding
6. ANS: B                   PTS: 1                   DIF: Easy                   REF: 8.2 Properties of Chords in a Circle  
LOC: 9.SS1               TOP: Shape and Space (Measurement)   KEY: Conceptual Understanding
7. ANS: A                   PTS: 1                   DIF: Easy                   REF: 8.2 Properties of Chords in a Circle  
LOC: 9.SS1               TOP: Shape and Space (Measurement)   KEY: Conceptual Understanding
8. ANS: C                   PTS: 1                   DIF: Easy                   REF: 8.3 Properties of Angles in a Circle  
LOC: 9.SS1               TOP: Shape and Space (Measurement)   KEY: Conceptual Understanding
9. ANS: A                   PTS: 1                   DIF: Easy                   REF: 8.3 Properties of Angles in a Circle  
LOC: 9.SS1               TOP: Shape and Space (Measurement)   KEY: Conceptual Understanding
10. ANS: D                  PTS: 1                  DIF: Moderate               REF: 8.3 Properties of Angles in a Circle  
LOC: 9.SS1               TOP: Shape and Space (Measurement)   KEY: Conceptual Understanding
11. ANS: D                  PTS: 1                  DIF: Moderate               REF: 8.3 Properties of Angles in a Circle  
LOC: 9.SS1               TOP: Shape and Space (Measurement)   KEY: Conceptual Understanding
12. ANS: D                  PTS: 1                  DIF: Moderate               REF: 8.3 Properties of Angles in a Circle  
LOC: 9.SS1               TOP: Shape and Space (Measurement)   KEY: Conceptual Understanding

### SHORT ANSWER

13. ANS:  
AC  
  
PTS: 1                   DIF: Easy                   REF: 8.1 Properties of Tangents to a Circle  
LOC: 9.SS1               TOP: Shape and Space (Measurement)   KEY: Conceptual Understanding
14. ANS:  
90°  
  
PTS: 1                   DIF: Easy                   REF: 8.1 Properties of Tangents to a Circle  
LOC: 9.SS1               TOP: Shape and Space (Measurement)   KEY: Conceptual Understanding

15. ANS:  
Yes.

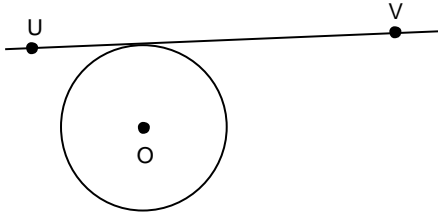

PTS: 1                      DIF: Moderate              REF: 8.1 Properties of Tangents to a Circle  
 LOC: 9.SS1                TOP: Shape and Space (Measurement)      KEY: Conceptual Understanding

16. ANS:  
 $v^\circ = 58^\circ, w^\circ = 30^\circ$

PTS: 1                      DIF: Moderate              REF: 8.1 Properties of Tangents to a Circle  
 LOC: 9.SS1                TOP: Shape and Space (Measurement)      KEY: Conceptual Understanding

17. ANS:  
 $m = 63.4, n^\circ = 60^\circ$

PTS: 1                      DIF: Moderate              REF: 8.1 Properties of Tangents to a Circle  
 LOC: 9.SS1                TOP: Shape and Space (Measurement)      KEY: Conceptual Understanding

18. ANS:  
DE

PTS: 1                      DIF: Easy                      REF: 8.2 Properties of Chords in a Circle  
 LOC: 9.SS1                TOP: Shape and Space (Measurement)      KEY: Conceptual Understanding

19. ANS:  
Answers may vary. For example:

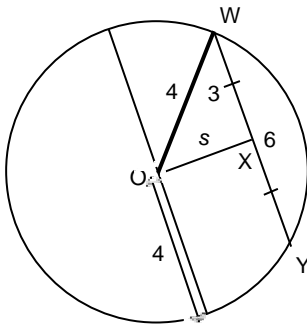

PTS: 1                      DIF: Easy                      REF: 8.2 Properties of Chords in a Circle  
 LOC: 9.SS1                TOP: Shape and Space (Measurement)      KEY: Conceptual Understanding

20. ANS:

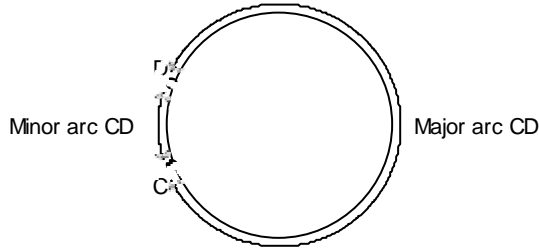

PTS: 1                      DIF: Easy                      REF: 8.3 Properties of Angles in a Circle  
LOC: 9.SS1                      TOP: Shape and Space (Measurement)                      KEY: Conceptual Understanding

21. ANS:

Inscribed angle

PTS: 1                      DIF: Easy                      REF: 8.3 Properties of Angles in a Circle  
LOC: 9.SS1                      TOP: Shape and Space (Measurement)                      KEY: Conceptual Understanding

22. ANS:

Inscribed angle:  $\angle PRQ$

Central angle:  $\angle POQ$

PTS: 1                      DIF: Easy                      REF: 8.3 Properties of Angles in a Circle  
LOC: 9.SS1                      TOP: Shape and Space (Measurement)                      KEY: Conceptual Understanding

23. ANS:

$180^\circ$

PTS: 1                      DIF: Easy                      REF: 8.3 Properties of Angles in a Circle  
LOC: 9.SS1                      TOP: Shape and Space (Measurement)                      KEY: Conceptual Understanding

24. ANS:

$y^\circ = 68^\circ, z^\circ = 136^\circ$

PTS: 1                      DIF: Easy                      REF: 8.3 Properties of Angles in a Circle  
LOC: 9.SS1                      TOP: Shape and Space (Measurement)                      KEY: Conceptual Understanding

25. ANS:

$y^\circ = 38^\circ, z^\circ = 52^\circ$

PTS: 1                      DIF: Moderate                      REF: 8.3 Properties of Angles in a Circle  
LOC: 9.SS1                      TOP: Shape and Space (Measurement)                      KEY: Conceptual Understanding

**PROBLEM**

26. ANS:

$$OV = 11 \text{ km} + 6400 \text{ km}$$

$$= 6411 \text{ km}$$

$$OH = 6400 \text{ km}$$

Use the Pythagorean Theorem in  $\triangle OHV$  to solve for HV.

$$HV^2 = OV^2 - OH^2$$

$$HV^2 = 6411^2 - 6400^2$$

$$HV^2 = 140\,921$$

$$HV = \sqrt{140\,921}$$

$$HV \approx 375.3944\dots$$

The vulture was about 375 kilometres from the horizon.

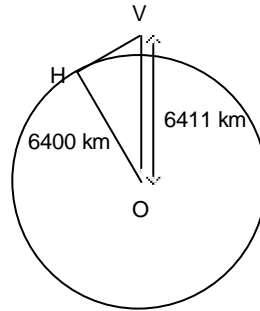

PTS: 1

DIF: Moderate

REF: 8.1 Properties of Tangents to a Circle

LOC: 9.SS1

TOP: Shape and Space (Measurement)

KEY: Problem-Solving Skills

27. ANS:

The distance from the centre of the mirror to the hook is: OT

So, the distance from the top of the mirror to the hook is:  $OT - 28 \text{ cm}$

Solve for OT.

$$OT^2 = 28^2 + 24^2$$

$$OT^2 = 1360$$

$$OT = \sqrt{1360}$$

$$OT \approx 36.8781\dots$$

So,

$$OT - 28 \text{ cm}$$

$$= 36.8781\dots \text{ cm} - 28 \text{ cm}$$

$$= 8.8781\dots \text{ cm}$$

So, the hook is about 8.9 cm above the mirror.

PTS: 1

DIF: Moderate

REF: 8.1 Properties of Tangents to a Circle

LOC: 9.SS1

TOP: Shape and Space (Measurement)

KEY: Problem-Solving Skills

28. ANS:

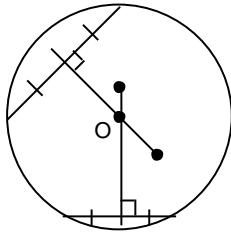

I know that the centre of the circle lies along the perpendicular bisector of a chord. So, when two different perpendicular bisectors are drawn, the centre of the circle is the point where they intersect.

PTS: 1                    DIF: Easy                    REF: 8.2 Properties of Chords in a Circle  
LOC: 9.SS1                TOP: Shape and Space (Measurement)  
KEY: Problem-Solving Skills | Communication

29. ANS:

- a) No. A chord joins two points on a circle. Given one point on a circle, the point farthest from that point is on the opposite side of the circle. The line connecting these two points passes through the centre of the circle, so it is a diameter.
- b) Yes. For example, in this circle, chord AB is shorter than radius OC.

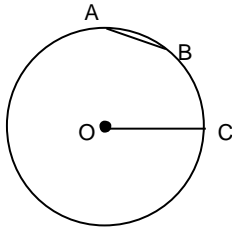

PTS: 1                    DIF: Moderate                REF: 8.2 Properties of Chords in a Circle  
LOC: 9.SS1                TOP: Shape and Space (Measurement)  
KEY: Problem-Solving Skills | Communication

30. ANS:

Draw two chords.

Construct the perpendicular bisectors of the chords.

The intersection of the perpendicular bisectors is the centre of the circle.

PTS: 1                    DIF: Moderate                REF: 8.2 Properties of Chords in a Circle  
LOC: 9.SS1                TOP: Shape and Space (Measurement)  
KEY: Problem-Solving Skills | Communication

31. ANS:  
Sketch a diagram.

Let  $d$  represent the distance from the chord to the centre of the circle.

Draw a radius from the centre to one end of the chord.

Label the known lengths.

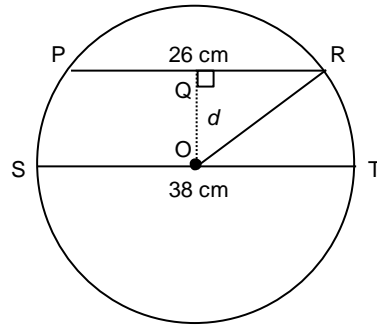

PR is a chord of the circle, and OQ is perpendicular to the chord, passing through the centre of the circle, so  $PQ = QR$  and QR is  $\frac{1}{2}$  of PR:

$$\begin{aligned} QR &= \frac{1}{2} (26 \text{ cm}) \\ &= 13 \text{ cm} \end{aligned}$$

ST is a diameter of the circle, and OR is a radius of the circle, so OR is  $\frac{1}{2}$  of ST:

$$\begin{aligned} ST &= \frac{1}{2} (38 \text{ cm}) \\ &= 19 \text{ cm} \end{aligned}$$

Use the Pythagorean Theorem in  $\triangle OQR$ .

$$d^2 + 13^2 = 19^2$$

$$d^2 = 19^2 - 13^2$$

$$d^2 = 192$$

$$d = \sqrt{192}$$

$$d \approx 13.8564\dots$$

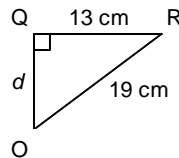

So, the chord is approximately 14 cm from the centre of the circle.

PTS: 1                      DIF: Moderate                      REF: 8.2 Properties of Chords in a Circle  
LOC: 9.SS1                      TOP: Shape and Space (Measurement)                      KEY: Conceptual Understanding

32. ANS:  
The sum of the central angles in a circle is  $360^\circ$ .

$$133^\circ + 107^\circ + x^\circ = 360^\circ$$

$$240^\circ + x^\circ = 360^\circ$$

$$x^\circ = 360^\circ - 240^\circ$$

$$x^\circ = 120^\circ$$

$\angle ACB$  is an inscribed angle and  $\angle AOB$  is a central angle subtended by the same arc.

$$\text{So, } \angle ACB = \frac{1}{2} \angle AOB$$

$$y^\circ = \frac{1}{2} \times 120^\circ$$

$$y^\circ = 60^\circ$$

OA and OB are radii, so  $\triangle AOB$  is isosceles with  $\angle OAB = \angle OBA = z^\circ$ .

The sum of the angles in a triangle is  $180^\circ$ , so in  $\triangle AOB$ :

$$z^\circ + z^\circ + 120^\circ = 180^\circ$$

$$2z^\circ + 120^\circ = 180^\circ$$

$$2z^\circ = 180^\circ - 120^\circ$$

$$2z^\circ = 60^\circ$$

$$z^\circ = \frac{60^\circ}{2}$$

$$z^\circ = 30^\circ$$

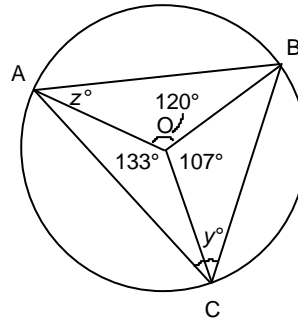

PTS: 1

DIF: Difficult

REF: 8.3 Properties of Angles in a Circle

LOC: 9.SS1

TOP: Shape and Space (Measurement)

KEY: Problem-Solving Skills